

**PRESSURE, DIFFERENTIAL PRESSURE,  
AND TEMPERATURE SWITCHES**



**FEATURES**

- 316 Stainless Steel Construction
- Hermetically Sealed Switch
- Convenient Field Adjustment
- 72" Leadwires with Strain Relief
- UL, cUL and ATEX Approved, Dual Seal Compliant
- Adjustable Ranges:

Pressure: 1 to 12,500 psi  
(68,9 mbar to 861,9 bar)

Differential Pressure:  
0.7" wcd to 150 psid  
(1,7 mbar to 10,3 bar)

Temperature: -130°F to 650°F  
(-90°C to 340°C)



### OVERVIEW

12 Series hazardous location switches are ideal for operation in tough applications where space is at a premium. A snap-action Belleville spring assembly is used to provide vibration resistance and prolonged switch life. The 316 stainless steel enclosure and hermetically sealed switch provide rugged protection from the environment. Approved for use in hazardous locations worldwide, the 12 Series is installed within applications ranging from offshore oil rigs to rotating equipment, and more.

### FEATURES

- UL, cUL and ATEX approved for Div. 1 or Zone 1 hazardous locations, CE compliant
- Dual seal compliant to ANSI/ISA 12.27.01
- Pressure switch wetted parts are NACE MR-0175 compliant
- Snap-acting Belleville spring for long life, vibration resistance and stability
- Optional Hastelloy® and Monel® sensor material for corrosive media
- Optional medium-pressure and high-pressure autoclave pressure connections
- Mounting bracket available for retrofit applications
- 72" leadwires with strain relief
- 3-year warranty



Temperature switch with optional armored capillary.

Optional Cover Locking Ring prevents incidental tampering.

Option M513 UL/CSA junction box

Option M423 ATEX junction box

Differential Pressure Model with mounting bracket

## APPLICATIONS

Triple approval (UL, cUL and ATEX) mean the 12 Series meets the demanding requirements of hazardous locations. Additionally, the 12 Series complies with ANSI/ISA 12.27.01, "secondary seal requirements for process sealing between electrical systems and flammable or combustible process fluids." It can be used in a variety of applications where space is at a premium. Ambient temperatures can range as low as -58°F (-50°C) or as high as 203°F (95°C). All metal wetted parts comply with NACE MR-0175 and the 316 stainless steel, type 4X enclosure rating assure long-term performance in the harshest environments.

Offshore Platforms



Chemical Plants & Refineries



Instrument Panels



Rotating Equipment

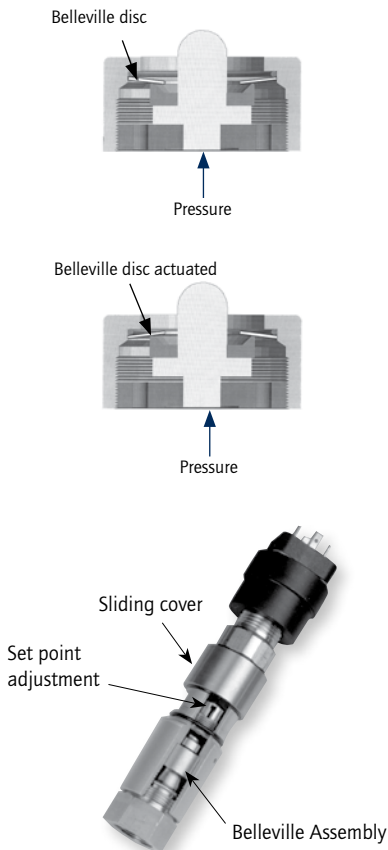

## TECHNOLOGY

At the heart of the 12 Series is a Belleville spring assembly. The spring is a small conical washer that transfers motion to a hermetically sealed 1 or 5 amp microswitch. Its 'snap-action' provides fast, positive contact transfer. The Belleville spring 'snaps over' when pressure is applied and 'snaps back' upon pressure release.

### Advantages:

- **Set point stability:** The switch performs under challenging environmental conditions such as vibration and temperature changes. In addition, minimal movement of components reduces sensor fatigue thereby increasing life and accuracy.
- **Resistance to vibration:** Preloading of the electrical switch helps reduce 'contact chatter.'
- **Small size:** Belleville springs are simple in appearance, but can deliver a heavy load with a relatively small deflection, contributing to a compact design.
- **Deadbands:** The Belleville is a 'negative-rate' snap acting device, so on-off deadband values are wider at the low end of the range. To minimize deadbands, select a model with a set point at the higher end of the range whenever possible.



## SPECIFICATIONS

<b>STORAGE TEMPERATURE</b>	-58° to 203°F (-50 to 95°C)
<b>OPERATING AMBIENT TEMPERATURE</b>	-58 to 203°F (-50 to 95°C). Set point shifts less than 1% of range for a 50°F (28°C) ambient temperature change. Slight ambient effects for 25-50' extra capillary length on temperature switch models, consult factory.
<b>MEDIA TEMPERATURE</b>	Pressure models: Sensor types 2, 7, 9: -50 to 400°F (-45 to 204°C) Sensor types 3, 4, 8: -20 to 200°F (-28 to 93°C) Sensor types 5, 6: 0 to 320°F (-18 to 160°C) Sensor type P: 0 to 200°F (-18 to 93°C); 20 to 250°F (-7 to 121°C) for optional Viton sensor Differential pressure models: Sensor type K: 0 to 180°F (-18 to 82°C); 20 to 250°F (-7 to 121°C) for optional Viton sensor Temperature models: See model chart.
<b>SET POINT REPEATABILITY</b>	Temperature models: ±1% of adjustable range Pressure models: Sensor types 2, P: ±1.5% of adjustable range Sensor types 3-9: ±1% of adjustable range Differential pressure models: K1 to K3: ±1%, K4 to K6: ±1.5% of adjustable range
<b>SHOCK</b>	Differential pressure and temperature models: set point repeats after 15 G's, 10 millisecond duration Pressure models: Set point repeats after 75 G's, 10 milliseconds
<b>VIBRATION</b>	Differential pressure and temperature models: Set point repeats after 2.5 G's, 10-2000 Hz. Pressure models: Set point repeats after 15 G's, 10-2000 Hz
<b>ENCLOSURE</b>	316 stainless steel
<b>ENCLOSURE CLASSIFICATION</b>	Certified to Enclosure Type 4X Class I, Division 1 product meets enclosure Type 7; Class II, Division I product meets enclosure type 9. Certified to IP66 requirements
<b>SWITCH OUTPUT</b>	Code S: One SPDT, hermetically sealed. Code D: Two SPDT for DPDT action, hermetically sealed
<b>ELECTRICAL RATINGS</b>	Code H: 5 A at 125/250 VAC, 5 A resistive and 3 A inductive at 28 VDC. Silver contacts Code L: 1 A at 125 VAC, 1 A resistive and 0.5 A inductive at 28 VDC Bifurcated gold contacts
<b>ELECTRICAL CONNECTION</b>	Code N: 1/2" NPT (male) with 72" leadwires Code M: M20 metric threads, 72" leads Option M515, 4 terminal DIN connector (DIN 43650 Form A) available SPDT only (does not meet Div. 1 or 2, or ATEX requirements.)

<b>WEIGHT</b>	Temperature models: approximately 1 lb 14 oz. (0,85 kg) Pressure models: approximately 12 ounces (0,34 kg) Differential models: approximately 3 lb (1,4 kg)
<b>TEMPERATURE ASSEMBLY</b>	Non-toxic oil fill; 6 feet 304 stainless steel. Optional lengths available
<b>TEMPERATURE DEADBAND</b>	Typically 2% of range under laboratory conditions (70°F ambient circulating bath at a rate of 1/2°F per minute change)
<b>PRESSURE CONNECTION</b>	1/2" NPT (female) or 1/4" NPT (female). Differential pressure: 1/8" NPT (female) Optional pressure connections available, see page 11.
<b>MOUNTING</b>	Pressure: May be pipe mounted or bracket mounted using kit 62169-13 Differential Pressure: Should be mounted using 2 mounting holes on sensor bracket Temperature: Mounting kit 62169-13 should be specified for new installations

## APPROVALS



### **UNITED STATES AND CANADA** **UL Listed, cUL Certified**

Class I, Division 1 and 2, Groups A, B, C & D  
Class II, Division 1 and 2, Groups E, F & G  
Class III  
Class I, Zone 1, Group IIC  
Enclosure Type 4X  
Pressure: UL 508 & 698; CSA C22.2 No. 14, 25 & 30 -  
File # E40857  
Temperature: UL 873, 1203; CSA C22.2 No. 24, 25 & 30 -  
File # E43374  
Dual seal certified to ISA 12.27.01 (meets CEC secondary  
seal requirements)



### **EUROPEAN UNION** **ATEX Directive 94/9/EC**

II 2 G Ex d IIC T6  
II 2 D T+85C  
Tamb = -50°C to +80°C  
IP 66  
UL International DEMKO A/S (N.B.# 0539)  
Certificate # DEMKO 07 ATEX 0717128X  
EN 60079-0, 60079-1, 50281-1-1

### **II 1 G EEx ia IIC T6 (OPTIONAL - code M405)**

Tamb = -50°C to +60°C  
UL International DEMKO A/S (N.B.# 0539)  
Certificate # DEMKO 03 ATEX 0335063  
EN 50014, 50020 & 50284

### **Pressure Equipment Directive (PED) 97/23/EC**

Compliant to PED  
Products rated lower than 7.5 psi are outside the scope of the  
PED



### **Low Voltage Directive (LVD) 73/23/EC & 93/68/EEC**

Compliant to LVD  
Products rated lower than 50 VAC and 75 VDC are outside the  
scope of the LVD  
The Low Voltage Directive does not apply to products for use in  
hazardous locations



### **RUSSIA**

Gosgortekhnadzor Permit **(OPTIONAL - code M406)**  
0ExIICT6  
Tamb = -50°C to +60°C  
1ExdIICT6X  
Tamb = -56°C to +85°C  
NANIO CCVE Certification Center  
Certificate # RRS 00-22739  
GOST R 51330.0, 51330.1, 51330.10 & 51330.14



### **UKRAINE**

Gosnadzorohrantruda Permit **(OPTIONAL - code M404)**  
1ExdIICT6X  
Tamb = -56°C to +85°C  
Certificate # 1868.04.30 - 31.62.4

## MODEL CHART

Model	Adjustable Range Lower end of range on fall; High end of range on rise	Deadband	Over Range Pressure*	Proof Pressure**
-------	--	----------	-------------------------	------------------

**Sensor Type 2**, 316 stainless steel 1/2" NPT (female) pressure connection and welded diaphragm, 23/32" orifice for clean out purposes. High proof pressure. Not recommended for high cycling applications. (NACE MR-0175 compliant)

	psi	bar	psi	bar	psi	bar	psi	bar
A	10 to 25	0,7 to 1,7	2 to 7	0,1 to 0,5	1000	68,9	2500	172,4
B	15 to 45	1,0 to 3,1	3 to 10	0,2 to 0,7	1000	68,9	2500	172,4
C	25 to 85	1,7 to 5,9	5 to 20	0,3 to 1,4	1000	68,9	2500	172,4
D	50 to 130	3,4 to 9,0	7 to 25	0,5 to 1,7	1500	103,4	2500	172,4
E	100 to 210	6,9 to 14,5	8 to 30	0,6 to 2,1	1500	103,4	2500	172,4
F	160 to 400	11,0 to 27,6	10 to 50	0,7 to 3,4	1500	103,4	2500	172,4
G	275 to 850	19,0 to 58,6	40 to 125	2,8 to 8,6	1500	103,4	2500	172,4

**Sensor Type 3**, 316L stainless steel 1/2" NPT (female) pressure connection, Teflon® coated Polyimide (Kapton®) diaphragm, Buna N O-ring, 1/2" orifice for clean out purposes. (NACE MR-0175 compliant)

**Sensor Type 4**, 316L stainless steel 1/4" NPT (female) pressure connection, Teflon® coated Polyimide (Kapton®) diaphragm, Buna N O-ring, 1/8" orifice. (NACE MR-0175 compliant)

	psi	bar	psi	bar	psi	bar	psi	bar
A	8 to 30	0,6 to 2,1	2 to 6	0,1 to 0,4	600	41,4	1000	68,9
B	15 to 55	1,0 to 3,8	3 to 8	0,2 to 0,6	600	41,4	1000	68,9
C	30 to 170	2,1 to 11,7	5 to 15	0,3 to 1,0	600	41,4	1000	68,9
D	100 to 370	6,9 to 25,5	15 to 50	1,0 to 3,4	600	41,4	1000	68,9
E	200 to 700	13,8 to 48,3	40 to 90	2,8 to 6,2	1500	103,4	3000	206,8
F	400 to 1500	27,6 to 103,4	100 to 250	6,9 to 17,2	3000	206,8	4500	310,3
G	1000 to 3200	68,9 to 220,6	100 to 500	6,9 to 34,5	6000	413,7	10000	689,5
H	2000 to 6000	137,9 to 413,7	400 to 800	27,6 to 55,2	8000	551,6	10000	689,5

\*Over Range Pressure: The maximum pressure that may be applied continuously without causing damage and maintaining set point repeatability.

\*\*Proof Pressure: The maximum pressure to which a pressure sensor may be occasionally subjected, which causes no permanent damage. The unit may require calibration (e.g., start-up, testing).

Kapton® is a registered trademark of E.I. DuPont de Nemours and Company.

Teflon® is a registered trademark of the DuPont Company.

Kalrez® and Viton® are registered trademarks of Dupont Performance Elastomers.

Hastelloy® is a registered trademark of Haynes International, Inc.

Monel® is a registered trademark of The Special Metals Corporation.

Aflas® is a registered trademark of Asahi Glass.

Model	Adjustable Range Lower end of range on fall; High end of range on rise	Deadband	Over Range Pressure*	Proof Pressure**
-------	--	----------	-------------------------	------------------

**Sensor Type 5**, 316L stainless steel 1/2" NPT (female) pressure connection and diaphragm (optional Hastelloy® C or Monel®), Viton® O-ring (optional Kalrez®, Ethylene Propylene, or Aflas®), 1/2" orifice for clean out purposes. (NACE MR-0175 compliant)

**Sensor Type 6**, 316L stainless steel 1/4" NPT (female) pressure connection and diaphragm (optional Hastelloy® C or Monel®), Viton® O-ring (optional Kalrez®, Ethylene Propylene, or Aflas®), 1/8" orifice. (NACE MR-0175 compliant)

	psi	bar	psi	bar	psi	bar	psi	bar
A	9 to 35	0,6 to 2,4	2 to 7	0,1 to 0,5	600	41,4	1000	68,9
B	25 to 65	1,7 to 4,5	3 to 10	0,2 to 0,7	600	41,4	1000	68,9
C	50 to 150	3,4 to 10,3	5 to 15	0,3 to 1,0	600	41,4	1000	68,9
D	100 to 350	6,9 to 24,1	15 to 50	1,0 to 3,4	600	41,4	1000	68,9
E	250 to 700	17,2 to 48,3	40 to 95	2,8 to 6,6	1500	103,4	3000	206,8
F	400 to 1500	27,6 to 103,4	100 to 300	6,9 to 20,7	3000	206,8	4500	310,3
G	1000 to 3200	68,9 to 220,6	100 to 500	6,9 to 34,5	6000	413,7	10000	689,5
H	2000 to 6000	137,9 to 413,7	400 to 1000	27,6 to 68,9	8000	551,6	10000	689,5

**Sensor Type 7**, 1/2" 316L stainless steel NPT (female) pressure connection and welded diaphragm. Large 23/32" orifice for clean out purposes. (NACE MR-0175 compliant)

	psi	bar	psi	bar	psi	bar	psi	bar
A	3 to 15	0,2 to 1,0	1 to 4	0,1 to 0,3	300	20,7	500	34,5
B	10 to 35	0,7 to 2,4	1 to 6	0,1 to 0,4	300	20,7	500	34,5
C	25 to 85	1,7 to 5,9	3 to 11	0,2 to 0,8	300	20,7	500	34,5
D	65 to 125	4,5 to 8,6	6 to 18	0,4 to 1,2	300	20,7	500	34,5

**Sensor Type 8**, 316L stainless steel 1/4" NPT (female) pressure connection, Teflon® coated Polyimide (Kapton®) diaphragm (optional Hastelloy® C or Monel®), Buna N O-ring (optional Kalrez®, Silicone, Ethylene Propylene, or Aflas®), 1/8" orifice. Non-Belleville actuation. (NACE MR-0175 compliant)

	psi	bar	psi	bar (unless noted)	psi	bar	psi	bar
A	3 to 25	0,2 to 1,7	0.5 to 4	34,5 mbar to 0,3 bar	600	41,4	1000	68,9
B	15 to 75	1,0 to 5,2	1 to 7	0,1 to 0,5	600	41,4	1000	68,9
C	25 to 150	1,7 to 10,3	1 to 12	0,1 to 0,8	600	41,4	1000	68,9
D	50 to 450	3,4 to 31,0	3 to 28	0,2 to 1,9	2000	137,9	3000	206,8
E	100 to 900	6,9 to 62,1	10 to 60	0,7 to 4,1	2000	137,9	3000	206,8
F	500 to 2500	34,5 to 172,4	20 to 140	1,4 to 9,7	6000	413,7	7500	517,1
G	700 to 4000	48,3 to 275,8	40 to 250	2,8 to 17,2	6000	413,7	7500	517,1

**Application Note:** The use of metallic diaphragms where higher pressure shock or heavy cycling is expected should be avoided. Sensor Type 7 or 9 should not be used where system or startup vacuum pressure might exceed 26" Hg Vac.

\***Over Range Pressure:** The maximum pressure that may be applied continuously without causing damage and maintaining set point repeatability.

\*\***Proof Pressure:** The maximum pressure to which a pressure sensor may be occasionally subjected, which causes no permanent damage. The unit may require calibration (e.g., start-up, testing).

## MODEL CHART

Model	Adjustable Range Lower end of range on fall; High end of range on rise	Deadband	Over Range Pressure*	Proof Pressure**
-------	--	----------	-------------------------	------------------

**Sensor Type 9**, 316L stainless steel 1/2" NPT (female) pressure connection and welded diaphragm. Large 23/32" orifice for clean-out purposes. Non-Belleville actuation. (NACE MR-0175 compliant)

	psi	bar	psi	mbar (unless noted)	psi	bar	psi	bar
A	1 to 15	0,1 to 1,0	0.5 to 2	34,5 to 137,9	300	20,7	500	34,5
B	3 to 50	0,2 to 3,4	0.5 to 4	34,5 to 275,8	300	20,7	500	34,5
C	5 to 100	0,3 to 6,9	1.0 to 8	0,1 to 06 bar	300	20,7	500	34,5

**Sensor Type P**, 316 stainless steel piston and Buna N O-Ring with 316 stainless steel 1/4" NPT (female) pressure connection. Non-Belleville actuation. (NACE MR-0175 compliant)

	psi	bar	psi	bar	psi	bar	psi	bar
1	300 to 1200	20,7 to 82,7	30 to 200	2,1 to 13,8	6000	413,7	10000	689,5
2	600 to 2600	41,4 to 179,3	50 to 350	3,4 to 24,1	6000	413,7	10000	689,5
3	1200 to 5500	82,7 to 379,2	100 to 800	6,9 to 55,2	7500	517,1	10000	689,5
4	4000 to 12,500	275,8 to 861,9	300 to 1250	20,7 to 86,2	14000	965,3	16000	1103,2

**Sensor Type P**, 316 stainless steel piston and Buna N O-Ring with 316 stainless steel 1/4" NPT (female) pressure connection. Belleville actuation. (NACE MR-0175 compliant)

	psi	bar	psi	bar	psi	bar	psi	bar
6	300 to 1200	20,7 to 82,7	30 to 200	2,1 to 13,8	6000	413,7	10000	689,5
7	600 to 2600	41,4 to 179,3	50 to 350	3,4 to 24,1	6000	413,7	10000	689,5
8	1200 to 5500	82,7 to 379,2	100 to 800	6,9 to 55,2	7500	517,1	10000	689,5
9	4000 to 12,500	275,8 to 861,9	300 to 1250	20,7 to 86,2	14000	965,3	16000	1103,2

\*Over Range Pressure: The maximum pressure that may be applied continuously without causing damage and maintaining set point repeatability.

\*\*Proof Pressure: The maximum pressure to which a pressure sensor may be occasionally subjected, which causes no permanent damage. The unit may require calibration (e.g., start-up, testing).

Application Note: The use of metallic diaphragms where higher pressure shock or heavy cycling is expected should be avoided. Sensor Type 7 to 9 should not be used where system or startup vacuum pressure might exceed 26" Hg Vac.

## DIFFERENTIAL PRESSURE MODEL CHART

Model	Adjustable Range Lower end of range on fall; High end of range on rise	Deadband	Working Pressure Range***	Proof Pressure**
-------	--	----------	---------------------------	------------------

**Sensor Type K**, epoxy coated aluminum pressure housing with Kapton® diaphragm, Buna N sealing diaphragms and 1/8" NPT (female) pressure connections. Non-Belleville actuation. 303/304 stainless steel mounting bracket attached.

**SPDT Switch (single pole double throw)‡**

	"wcd	mbar	"wc	mbar	psi (unless noted)	bar	psi	bar
1	0.7 to 10	1,7 to 24,9	0.2 to 1	0,5 to 2,5	30 "Hg Vac to 200	-1,0 to 13,8	400	27,6
2	3 to 20	7,5 to 49,8	0.3 to 1.5	0,7 to 3,7	30 "Hg Vac to 200	-1,0 to 13,8	400	27,6
3	10 to 150	24,9 to 373,4	0.3 to 5	0,7 to 12,4	30 "Hg Vac to 200	-1,0 to 13,8	400	27,6
	psid	bar	psi	bar (unless noted)	psi (unless noted)	bar	psi	bar
4	2 to 20	0,1 to 1,4	0.3 to 1.5	20,7 to 103,4 mbar	30 "Hg Vac to 1200	-1,0 to 82,7	2500	172,4
5	5 to 80	0,3 to 5,5	1 to 8	0,1 to 0,6	30 "Hg Vac to 1200	-1,0 to 82,7	2500	172,4
6	10 to 150	0,7 to 10,3	1 to 10	0,1 to 0,7	30 "Hg Vac to 1200	-1,0 to 82,7	2500	172,4

**Sensor Type K**, epoxy coated aluminum pressure housing with Kapton® diaphragm, Buna N sealing diaphragms and 1/8" NPT (female) pressure connections. Non-Belleville actuation. 303/304 stainless steel mounting bracket attached.

**DPDT Switch (double pole double throw)‡**

	"wcd	mbar	"wc	mbar	psi (unless noted)	bar	psi	bar
1	0.7 to 10	1,7 to 24,9	0.2 to 1.5	0,5 to 3,7	30 "Hg Vac to 200	-1,0 to 13,8	400	27,6
2	3 to 20	7,5 to 49,8	0.3 to 2	0,7 to 5,0	30 "Hg Vac to 200	-1,0 to 13,8	400	27,6
3	10 to 150	24,9 to 373,4	0.3 to 8	0,7 to 19,9	30 "Hg Vac to 200	-1,0 to 13,8	400	27,6
	psid	bar	psi	bar	psi	bar	psi	bar
4	2 to 20	0,1 to 1,4	0.3 to 3	20,7 to 206,8 mbar	30 "Hg Vac to 1200	-1,0 to 82,7	2500	172,4
5	5 to 80	0,3 to 5,5	1 to 10	0,1 to 0,7	30 "Hg Vac to 1200	-1,0 to 82,7	2500	172,4
6	10 to 150	0,7 to 10,3	1 to 15	0,1 to 1,0	30 "Hg Vac to 1200	-1,0 to 82,7	2500	172,4

## TEMPERATURE MODEL CHART (Standard capillary: 6ft, 304 st/st)

Installation may require optional mounting bracket kit (P/N 62169-13, see page 14)

Model	Adjustable Range		Max. Temperature		Bulb Size
	°F	°C	°F	°C	
R1	-130 to 120	-90 to 48.9	170	76.7	3/8 O.D. x 4-7/8"
R2	0 to 150	-17.8 to 65.6	200	93.3	3/8 O.D. x 7-1/4"
R3	50 to 300	10 to 148.9	350	176.7	3/8 O.D. x 4-7/8"
R4	150 to 650	65.6 to 343.3	700	371.1	3/8 O.D. x 4"

\*\*Proof Pressure: The maximum pressure to which a pressure sensor may be occasionally subjected, which causes no permanent damage. The unit may require calibration (e.g., start-up, testing)

\*\*\*Working Pressure Range: The pressure range within which two opposing sensors can be safely operated and still maintain set point adjustability.

‡See page 10 on building a part number for switch codes.



# 12 Series

## 12 Series

### HOW TO ORDER

Step 1: Select letter or number "Codes" to make up a part number

Part #	12	S	H	S	N	2	A	M201
	Series	Housing Material	Electrical Rating	Number of Switches	Electrical Conduit	Sensor Type	Model	Options

(see next page)

ORDERING CODE	DESCRIPTION	12	S	H	S	N	2	A	M201
<b>SERIES 12 DESIGNATION</b>	_____								
12	Designation for Spectra 12 product line								
<b>HOUSING MATERIAL</b>	_____								
S	316 Stainless Steel								
<b>ELECTRICAL RATING*</b>	_____								
L	1 amp								
H	5 amp								
<b>NUMBER OF SWITCHES</b>	_____								
S	SPDT								
D	DPDT								
<b>ELECTRICAL CONDUIT</b>	_____								
N	1/2" NPT male								
M	M20 metric thread								
<b>SENSOR TYPE, PRESSURE CONNECTION OR BULB &amp; CAPILLARY</b>	_____								
2	Welded 316 stainless steel diaphragm, 1/2" NPT (female) pressure connection								
3	Teflon® coated Polyimide (Kapton®) diaphragm, Buna N O-ring, 1/2" NPT (female) pressure connection								
4	Teflon® coated Polyimide (Kapton®) diaphragm, Buna N O-ring, 1/4" NPT (female) pressure connection								
5	316L stainless steel diaphragm, Viton® O-ring, 1/2" NPT (female) pressure connection								
6	316L stainless steel diaphragm, Viton® O-ring, 1/4" NPT (female) pressure connection								
7	Welded 316L stainless steel diaphragm, 1/2" NPT (female) pressure connection								
8	Kapton® diaphragm, Buna N O-ring, 1/4" NPT (female) pressure connection (non-Belleville actuation)								
9	316L stainless steel welded diaphragm, 1/2" NPT (female) pressure connection (non-Belleville actuation)								
P	316 stainless steel piston, Buna N O-ring, 1/4" NPT (female) 316 stainless steel pressure connections (Belleville and non-Belleville actuated models)								
K	Kapton® diaphragm, Buna N sealing diaphragm, 1/8" NPT (female) pressure connections (non-Belleville actuation)								
R	Remote bulb & capillary, temperature								

### MODELS, RANGE

A, B, C, D, E, See model chart for range specifications

F, G, H, 1, 2,

3, 4, 5, 6, 7, 8, 9

\* All switches have limited DC capabilities. Consult factory for details.

**OPTIONS**

- M201 Factory set switch, specify increasing or decreasing pressure
- M277 Range in kPa or mPa on nameplate, factory selected. NOT AVAILABLE ON TEMPERATURE VERSIONS
- M278 Range in kg/cm<sup>2</sup> on nameplate. NOT AVAILABLE ON TEMPERATURE VERSIONS
- M404 Flameproof compliance for Ukraine per Gosnadzorhnantruda standards
- M405 European ATEX intrinsic safety compliance
- M406 Flameproof and intrinsic safety compliance per Russian Gosgortekhnadzor standards
- M421 Gosgortekhnadzor flameproof junction box, pre-wired (not UL approved or ATEX certified) (NOT AVAILABLE ON M20 METRIC THREAD ELECTRICAL CONDUIT VERSION)
- M423 ATEX flameproof compliant junction box, pre-wire (not UL approved) (NOT AVAILABLE ON M20 METRIC THREAD ELECTRICAL CONDUIT VERSION)
- M430 Cover lock
- M444 Paper ID tag
- M446 Stainless steel ID tag and wire attachment
- M460 External ground screw; required for non-metallic conduit systems (ATEX installations only)
- M480 316 Stainless steel construction, pressure connections only, sensor material cannot be changed. AVAILABLE SENSOR TYPE K ONLY.
- M511 1/4" NPT (male) pressure connection for sensor types 3, 4, 5, 6 and 8 only
- M513 UL/CSA approved, explosion proof junction box, pre-wired (not approved for ATEX or as enclosure type 4X). NOT AVAILABLE ON M20 METRIC THREAD ELECTRICAL CONDUIT VERSION
- M515 DIN Connector-4 terminal; conforms to DIN 43650 Form A, (not approved for Class I Div. 1 & 2 or ATEX flame proof requirements). NOT AVAILABLE ON DPDT OR METRIC THREAD ELECTRICAL CONDUIT VERSIONS
- M521 LF4 Medium pressure autoclave 1/4" (female); AVAILABLE SENSOR TYPES P4 & P9 ONLY
- M522 LM4 Medium pressure autoclave 1/4" (male); AVAILABLE SENSOR TYPES P4 & P9 ONLY
- M523 LF6 Medium pressure autoclave 3/8" (female); AVAILABLE SENSOR TYPES P4 & P9 ONLY
- M524 LM6 Medium pressure autoclave 3/8" (male); AVAILABLE SENSOR TYPES P4 & P9 ONLY
- M525 HF4 High pressure autoclave 1/4" (female); AVAILABLE SENSOR TYPES P4 & P9 ONLY
- M526 HM4 High pressure autoclave 1/4" (male); AVAILABLE SENSOR TYPES P4 & P9 ONLY
- M527 HF6 High pressure autoclave 3/8" (female); AVAILABLE SENSOR TYPES P4 & P9 ONLY
- M528 HM6 High pressure autoclave 3/8" (male); AVAILABLE SENSOR TYPES P4 & P9 ONLY
- M540 Viton® construction (deadband and low end of range will increase slightly): SENSOR TYPE K wetted parts include Kapton diaphragm, Viton® O-ring and sealing diaphragm, aluminum pressure connection; SENSOR TYPE 8 wetted parts include stainless steel diaphragm and pressure connection with Viton O-ring; SENSOR TYPE P wetted parts include stainless steel piston and pressure connection with Viton O-ring.
- M541 Ethylene propylene (EPDM) O-ring for sensor types 5, 6, & P only
- M550 Oxygen service cleaning; internal construction and materials may change (includes Viton® diaphragm and/or O-ring when applicable). NOT AVAILABLE ON SENSOR TYPES 3, 4, AND 8
- M924 7/16-20 SAE (female) stainless steel pressure connection. AVAILABLE SENSOR TYPE 6 ONLY
- NC1 NACE certificate; NOT AVAILABLE FOR SENSOR TYPE K AND TEMPERATURE MODELS

**ACCESSORIES**

- 62169-13 Mounting bracket kit (available with pressure and temperature models only)
- 62169-31 ATEX flameproof compliant junction box and terminal kit, not pre-wired (see option code M423)
- 6361-694 Junction box and terminal kit, not pre-wired (see option code M513 for description)

## OPTIONS FOR TEMPERATURE MODELS

### OPTIONAL SENSOR MATERIALS FOR CORROSIVE MEDIA AVAILABLE SENSOR TYPES 5, 6, and 8

XD002	Hastelloy® C diaphragm
XD003	Monel® diaphragm
XP112	Hastelloy® C pressure connection
XP113	Monel® pressure connection
XR211	Kalrez® O-ring
XR213	Ethylene propylene O-ring
XR214	Aflas® O-ring

### UNION CONNECTORS\*

Option	Replacement Number	Description
	<u>304 Stainless Steel</u>	
W028	SD6213-28	1/2" NPT w/ 3/4" bushing
W046	SD6213-46	3/4" NPT
W050	SD6213-50	1/2" NPT

### THERMOWELLS

For all bulb & capillary switches

	<u>316 Stainless Steel</u>	
W076	SD6225-76	3/4" NPT, 4.5" BT
W193	SD6225-193	1/2" NPT, 4.5" BT
W119	SD6225-119	3/4" NPT, 7.5" BT
W177	SD6225-177	1/2" NPT, 7.5" BT

### OPTIONAL LENGTHS

Optional capillary length to ±50' available in 304 st/st. Armor or Teflon® capillary protection available to lengths less than or equal to capillary length. Consult UE for additional information.

‡Consult UE regarding repeatability and ambient effects on capillary lengths over 30'.

\*Dimensional drawings for union connectors and thermowells may be found at [www.ueonline.com](http://www.ueonline.com)

## DIMENSIONAL DRAWINGS

Dimensional drawings for all models may be found at [www.UEonline.com](http://www.UEonline.com)

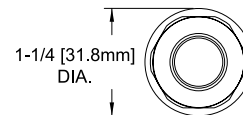

### PRESSURE & TEMPERATURE SWITCH / CONNECTION CHART

Type	Description	Dimension "A"		Dimension "B"		Dimension "C"	
		Inches	mm	Inches	mm	Inches	mm
2	1/2" NPT (female)	4.4	111.1	0.7	16.5	1-1/16	27.0
3, 5	1/2" NPT (female)	4.4	111.1	0.6	15.2	1-1/16	27.0
4, 6, 8	1/4" NPT (female)	4.4	111.1	0.6	15.2	1-1/16	27.0
7, 9	1/2" NPT (female)	4.0	100.3	1.6	40.6	1-1/8	28.6
P1-P9	1/4" NPT (female)	4.4	111.1	1.0	25.4	1-1/16	27.0
K1-K3	1/8" NPT (female)	4.4	111.1	1.7	42.9	N/A	N/A
K4-K6	1/8" NPT (female)	4.4	111.1	1.8	44.5	N/A	N/A
R1-R4	Temperature	4.4	111.1	0.6	15.2	N/A	N/A
M521	LF4 Autoclave 1/4" (female)	4.4	111.1	1.2	29.7	1-1/16	27.0
M522	LM4 Autoclave 1/4" (male)	4.4	111.1	1.4	34.8	1-1/16	27.0
M523	LF6 Autoclave 3/8" (female)	4.4	111.1	1.4	36.1	1-1/16	27.0
M524	LM6 Autoclave 3/8" (male)	4.4	111.1	1.5	38.4	1-1/16	27.0
M525	HF4 Autoclave 1/4" (female)	4.4	111.1	1.2	29.7	1-1/16	27.0
M526	HM4 autoclave 1/4" (male)	4.4	111.1	1.3	32.8	1-1/16	27.0
M527	HF6 Autoclave 3/8" (female)	4.4	111.1	1.4	36.1	1-1/16	27.0
M528	HM6 Autoclave 3/8" (male)	4.4	111.1	1.5	37.6	1-1/16	27.0

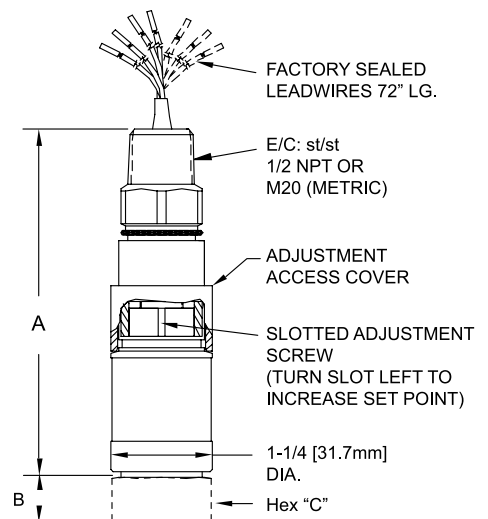

**DIMENSIONAL DRAWINGS**

Dimensional drawings for all models may be found at [www.UEonline.com](http://www.UEonline.com)

**SENSOR DETAILS**

**Pressure**

**TYPES 2, 3, 5 SENSOR**

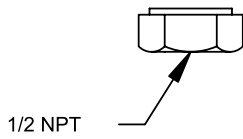

**TYPES 4, 6, 8 P1-P9**

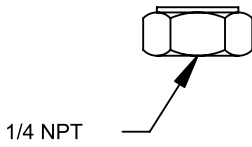

**TYPES 7, 9 SENSOR**

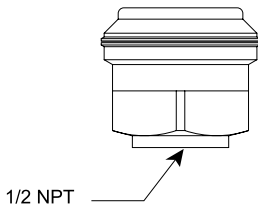

**TYPES P4 & P9 SENSOR ONLY**

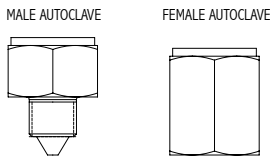

*See Options for autoclave types*

\*Shown with mounting bracket attached

**Differential Pressure**

**TYPE K1-K3\***

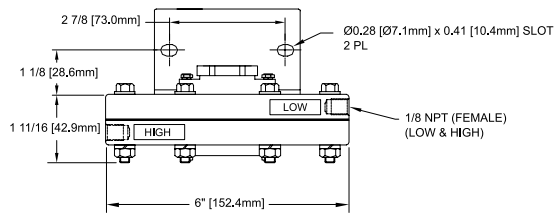

**TYPES K4-K6\***

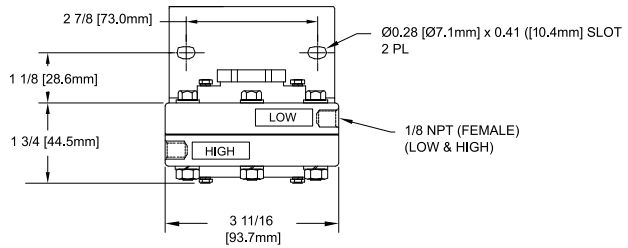

**Temperature**

**TYPES R1-R4**

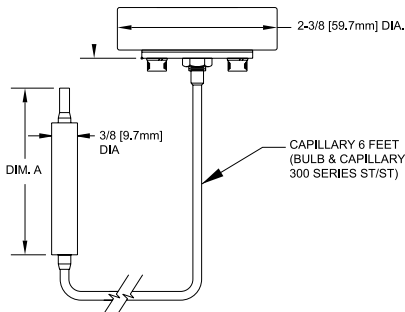

BULB DIMENSIONS		
Dimension A		
Types	Inches	mm
R1	4-7/8"	123.8
R2	7-1/4"	184.2
R3	4-7/8"	123.8
R4	4"	101.6

## DIMENSIONAL DRAWINGS

Dimensional drawings for all models may be found at [www.UEonline.com](http://www.UEonline.com)

**OPTIONAL MOUNTING BRACKET KIT  
62169-13**

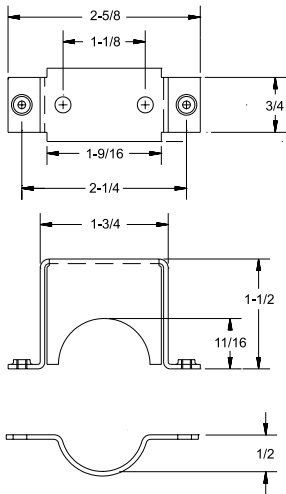

**OPTION M423 JUNCTION BOX**

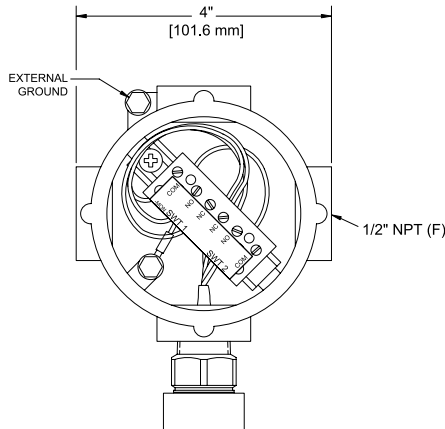

**OPTION M430 COVER LOCK**

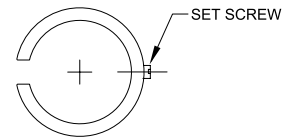

**OPTION M460 EXTERNAL  
GROUNDING SCREW**

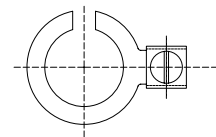

**OPTION M513 JUNCTION BOX**

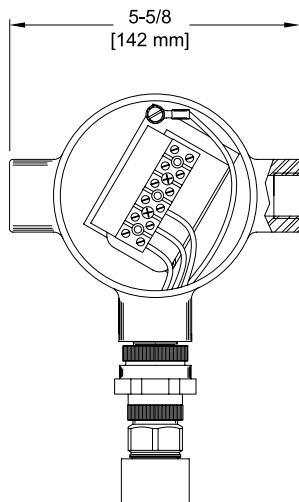

Does not meet ATEX or enclosure type 4X requirements.

**OPTION M515 DIN CONNECTOR.**

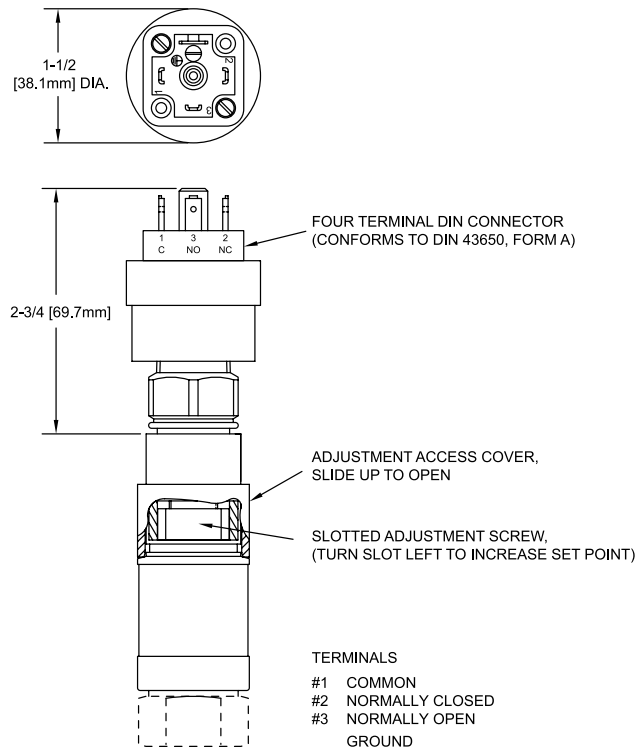

Does not meet Div 1 or 2, or ATEX requirements.

ALTERNATIVE PRODUCTS FROM UE

**120 Series**

- Explosion-proof line of pressure, differential pressure, and temperature models with wide selection of ranges, sensors and pressure connections
- UL, cUL, ATEX certified for hazardous locations
- Single or dual switch outputs
- Internal or external set point adjustment



**TX200 Series Pressure Transmitters**

- Welded, hermetically sealed, 316 Stainless steel construction
- Ranges 0 to 15 psi up to 0 to 25,000 psi
- Choice of field adjustable or fixed range models
- 4-20 mA or 1-5 VDC output



**117 Series**

- Single Switch for Corrosive and Hazardous Division 2 Locations
- Compact pressure, differential pressure and temperature models
- Hermetically-sealed SPDT and DPDT output
- Epoxy-coated weather-tight design houses stainless steel internal Construction
- Convenient terminal block wiring



**One Series 2-Wire & 4-Wire Electronic Pressure and Temperature Switches with I Am Working Diagnostics Signal**

- Solid-state reliability with health-checking diagnostics
- Available with innovative low power "2-Wire" model for discrete input to PLC's or DCS; or models to switch 24-280 VAC @ 10 Amps
- Enclosure type 4X design, approved for Class I, Division 2 hazardous or intrinsically safe locations
- Digital display and tamper-proof keypad adjustment of setpoint and deadband



**400 Series Multi-Output Switch**

- 1, 2, and 3 switch output may be separated up to 100% of range
- Wide selection of pressure, differential pressure, and temperature ranges
- Setting via reference dial or hex screw adjustment
- Weathertight 4x design ideal for ordinary location applications.



## RECOMMENDED PRACTICES AND WARNINGS

United Electric Controls Company recommends careful consideration of the following factors when specifying and installing UE pressure and temperature units. Before installing a unit, the Installation and Maintenance instructions provided with unit must be read and understood.

- To avoid damaging unit, proof pressure and maximum temperature limits stated in literature and on nameplates must never be exceeded, even by surges in the system. Operation of the unit up to maximum pressure or temperature is acceptable on a limited basis (e.g., start-up, testing) but continuous operation must be restricted to the designated adjustable range. Excessive cycling at maximum pressure or temperature limits could reduce sensor life.
- A back-up unit is necessary for applications where damage to a primary unit could endanger life, limb or property. A high or low limit switch is necessary for applications where a dangerous runaway condition could result.
- The adjustable range must be selected so that incorrect, inadvertent or malicious setting at any range point cannot result in an unsafe system condition.
- Install unit where shock, vibration and ambient temperature fluctuations will not damage unit or affect operation. When applicable, orient unit so that moisture does not enter the enclosure via the electrical connection. When appropriate, this entry point should be sealed to prevent moisture entry.
- Unit must not be altered or modified after shipment. Consult UE if modification is necessary.
- Monitor operation to observe warning signs of possible damage to unit, such as drift in set point or faulty display. Check unit immediately.
- Preventative maintenance and periodic testing is necessary for critical applications where damage could endanger property or personnel.
- Electrical ratings stated in literature and on nameplate must not be exceeded. Overload on a switch can cause damage, even on the first cycle. Wire unit according to local and national electrical codes, using wire size recommended in installation sheet.
- Do not mount unit in ambient temp. exceeding published limits.

## LIMITED WARRANTY

Seller warrants that the product hereby purchased is, upon delivery, free from defects in material and workmanship and that any such product which is found to be defective in such workmanship or material will be repaired or replaced by Seller (Ex-works, Factory, Watertown, Massachusetts. INCOTERMS); provided, however, that this warranty applies only to equipment found to be so defective within a period of 36 months from the date of manufacture by the Seller. Seller shall not be obligated under this warranty for alleged defects which examination discloses are due to tampering, misuse, neglect, improper storage, and in any case where products are disassembled by anyone other than authorized Seller's representatives. EXCEPT FOR THE LIMITED WARRANTY OF REPAIR AND REPLACEMENT STATED ABOVE, SELLER DISCLAIMS ALL WARRANTIES WHATSOEVER WITH RESPECT TO THE PRODUCT, INCLUDING ALL IMPLIED WARRANTIES OF MERCHANTABILITY OR FITNESS FOR ANY PARTICULAR PURPOSE.

## LIMITATION OF SELLER'S LIABILITY

SELLER'S LIABILITY TO BUYER FOR ANY LOSS OR CLAIM, INCLUDING LIABILITY INCURRED IN CONNECTION WITH (I) BREACH OF ANY WARRANTY WHATSOEVER, EXPRESSED OR IMPLIED, (II) A BREACH OF CONTRACT, (III) A NEGLIGENT ACT OR ACTS (OR NEGLIGENT FAILURE TO ACT) COMMITTED BY SELLER, OR (IV) AN ACT FOR WHICH STRICT LIABILITY WILL BE INPUTTED TO SELLER, IS LIMITED TO THE "LIMITED WARRANTY" OF REPAIR AND/OR REPLACEMENT AS SO STATED IN OUR WARRANTY OF PRODUCT. IN NO EVENT SHALL THE SELLER BE LIABLE FOR ANY SPECIAL, INDIRECT, CONSEQUENTIAL OR OTHER DAMAGES OF A LIKE GENERAL NATURE, INCLUDING, WITHOUT LIMITATION, LOSS OF PROFITS OR PRODUCTION, OR LOSS OR EXPENSES OF ANY NATURE INCURRED BY THE BUYER OR ANY THIRD PARTY.

*UE specifications subject to change without notice.*

## U.S. SALES OFFICES

United Electric Controls  
31 Old Stage Road  
Hampton Falls, NH 03844  
Phone: 617-899-1132  
email: [northeastsales@ueonline.com](mailto:northeastsales@ueonline.com)

United Electric Controls  
28 N. Wise Ave.  
Freeport, IL 61032  
Phone: 815-341-2588  
email: [midwestsales@ueonline.com](mailto:midwestsales@ueonline.com)

United Electric Controls  
1022 Vineyard Drive  
Conyers, GA 30013  
Phone: 770-335-9802  
email: [southeastsales@ueonline.com](mailto:southeastsales@ueonline.com)

United Electric Controls  
5829 Grazing Court  
Mason, OH 45040  
Phone: 513-535-5486  
email: [midatlanticsales@ueonline.com](mailto:midatlanticsales@ueonline.com)

United Electric Controls  
102 Salazar Court  
Clayton, CA 94517  
Phone: 925-408-5997  
email: [westcoastsales@ueonline.com](mailto:westcoastsales@ueonline.com)

United Electric Controls  
27 Summit Terrace  
Sparta, NJ 07871  
Phone: 973-271-2550  
email: [easternsales@ueonline.com](mailto:easternsales@ueonline.com)

United Electric Controls  
4306 Whickham Drive  
Fulshear, TX 77441  
Phone: 832-457-6138  
email: [southwestsales@ueonline.com](mailto:southwestsales@ueonline.com)

United Electric Controls  
5201 Arbor Court  
Odessa, TX 79762  
Phone: 432-770-4164  
email: [westtexasales@ueonline.com](mailto:westtexasales@ueonline.com)

## CANADA

EASTERN  
68 Mosley Crescent  
Brampton, Ontario  
Canada L6Y 5C8  
Phone: 905-455-5131  
FAX: 905-455-5131

WESTERN  
148 Silver Ridge Close N.W.  
Calgary, Alberta  
Canada T3B 3T4  
Phone: 403-247-3724  
FAX: 403-247-3724

## INTERNATIONAL OFFICES

CHINA  
United Electric Controls, *Shanghai Office*  
Room 1011, 10th Flr,  
Huai Hai Zhonghua Building  
No. 885, Renmin Road, Luwan District  
Shanghai 200010, P.R. China  
Phone: +8621-6255 8059  
email: [chinasales@ueonline.com](mailto:chinasales@ueonline.com)

United Electric Controls, *Beijing Office*  
Room 1006, Jainhao International Bldg.  
Block D, No. 116  
Zizhuyuanlu, Haidian District  
Beijing, China 100089  
Phone: +86-10-5893-0518  
email: [beijingsales@ueonline.com](mailto:beijingsales@ueonline.com)

EASTERN EUROPE & SCANDINAVIA  
United Electric Controls  
05-806 Komorow  
Kujawska 5, Poland  
Phone: +48 22 499 4804  
email: [easterneuropesales@ueonline.com](mailto:easterneuropesales@ueonline.com)

GERMANY  
United Electric Controls  
An Der Zentlinde 21  
D-64711 Erbach, Germany  
Phone: 496-062-7400  
email: [europesales@ueonline.com](mailto:europesales@ueonline.com)

INDIA  
United Electric Controls  
House no. 7, Kamalkunj Society  
Nizampura,  
Baraoda (Gujarat), India  
Phone: +91 (-265) -2788654  
email: [indiasales@ueonline.com](mailto:indiasales@ueonline.com)

ASIA-PACIFIC  
United Electric Controls, Far East  
No. 1-2-2, 2nd Floor  
Jalan 4/101C  
Cheras Business Centre  
Batu 5, Jalan Cheras  
56100 Kuala Lumpur, Malaysia  
Phone: 603-9133-4122  
email: [fareastsales@ueonline.com](mailto:fareastsales@ueonline.com)

MEXICO  
United Electric Controls  
Zacatecas # 206, Suite 20  
Col Guadalupe CP 89120  
Tampico, Tamaulipas Mexico  
Phone: 833-217-5201  
email: [latinamericasales@ueonline.com](mailto:latinamericasales@ueonline.com)

RUSSIA  
United Electric Controls, Moscow  
Elninskaya str., 15-140  
Moscow, 121552, Russia  
Phone: +7 (495) 792-88-06  
email: [russiansales@ueonline.com](mailto:russiansales@ueonline.com)



Ihr Ansprechpartner für  
Beratung, Verkauf, Service



Kundert Ingenieure AG

Ilfangstrasse 6, CH – 8952 Schlieren

Tel. +41 44 755 42 42, Fax +41 44 755 42 43

[www.kundert-ing.ch](http://www.kundert-ing.ch) [automation@kundert-ing.ch](mailto:automation@kundert-ing.ch)