



Features

- The Model 1600A Vacuum Regulator controls pressure in high flow systems above and below atmospheric pressure.
- The single unit controls vacuum and positive pressure.
- Control sensitivity of 1" water column allows use in precision applications.
- Large Supply and Exhaust Valves provide high forward and exhaust flows.
- Soft Supply and Exhaust Valve seats minimize air consumption.
- A balanced Supply Valve minimizes the effect of supply pressure variation.
- An Aspirator Tube compensates downstream pressure drop under flow conditions.
- A separate Control Chamber isolates the diaphragm from the main flow to eliminate hunting and buzzing.
- Unit construction lets you service the Model 1600 without removing it from the line.

Operating Principles

When you adjust the Range Screw to a specific setpoint, the Range Spring exerts a downward force on the top of the Signal Diaphragm. The Negative Bias Spring creates an upward force on the bottom of the Signal Diaphragm. The upward net force opens the Relief Valve (vacuum supply) to let Vacuum pressure flow through the Outlet Port and the Aspirator Tube to the Control Chamber. As the setpoint is reached, the decrease in pressure lets the Diaphragm Assembly move downward to close the Relief Valve (vacuum supply).

When the vacuum pressure increases above the setpoint, the Diaphragm Assembly moves downward to open the Supply Valve (positive pressure) to maintain Output pressure.

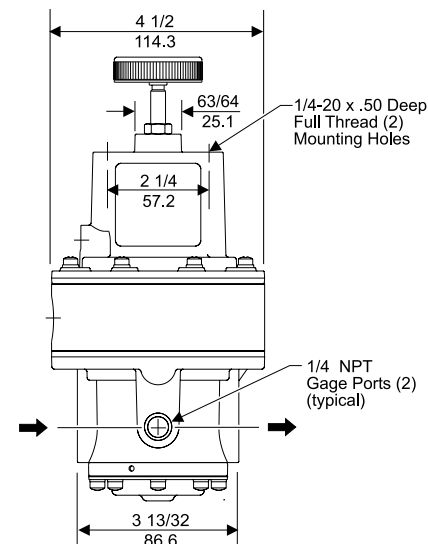
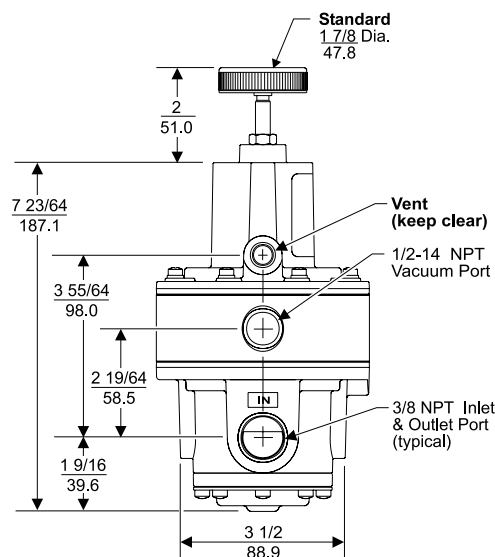
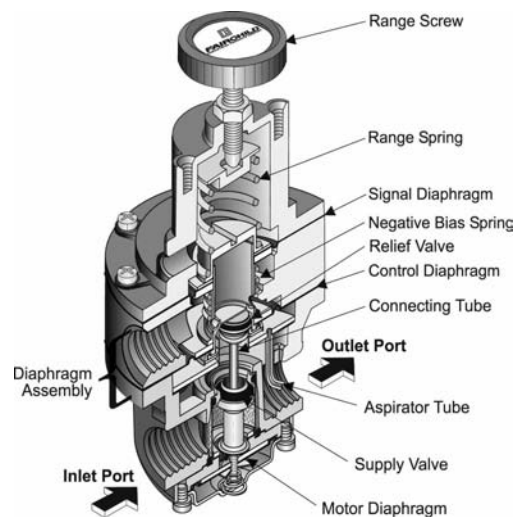

Technical Information

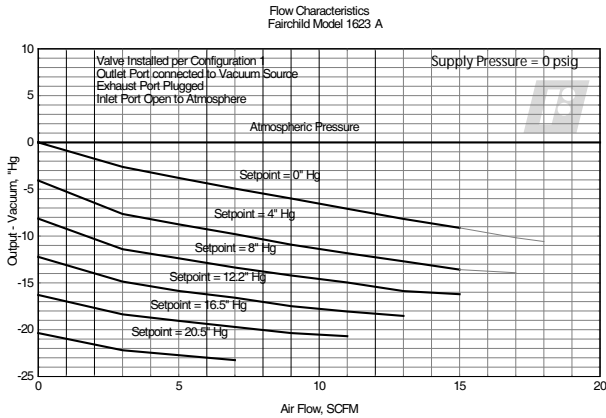

Specifications

Supply Pressure

250 psig, [17.0 BAR], (1700 kPa) Maximum

Flow Capacity (SCFM)

28 (48 m³/HR) @ 29" Hg vacuum with inlet port open to atmosphere.

150 (255 m³/HR) @ 100 psig, [7.0 BAR], (700 kPa) supply & 20 psig, [1.5 BAR], (150 kPa) setpoint

Exhaust Capacity

20 (34 m³/HR) where downstream pressure is 5 psig, [.35 BAR], (35 kPa) above 20 psig, [1.5 BAR], (150 kPa) setpoint

Supply Pressure Effect

Less than 0.1 psig, [.007 BAR], (0.7 kPa) for 100 psig, [7.0 BAR], (700 kPa) change in supply pressure

Sensitivity

1" (2.54 cm) Water Column

Ambient Temperature

-40°F to +200°F, (-40°C to +93°C)

Materials of Construction

Body and HousingAluminum
 TrimZinc Plated Steel, Brass
 DiaphragmsNitrile on Dacron

Catalog Information

Catalog Number

1 6 A

Pressure Range

psig	[BAR]	(kPa)
Vacuum - 10	[Vacuum -0.7]	(Vacuum - 70)...
Vacuum - 30	[Vacuum -2.0]	(Vacuum - 200)...
Vacuum - 150	[Vacuum - 10]	(Vacuum - 1000)...

2
 3
 6

Pipe Size

3/8" NPT
 1/2" NPT
 3/4" NPT

3
 4
 6

Options

BSPP (Parallel)¹
 Fluorcarbon
 Tamper Proof
 BSPT (Tapered).....

H
 J
 T
 U

¹ BSPP Threads in Inlet & Outlet Ports Only. Others BSPT.

Installation

For installation instructions, refer to the *Fairchild Model 1600A Vacuum Regulator Installation, Operation and Maintenance Instructions, IS-1001600A*.

Ihr Ansprechpartner für
 Beratung, Verkauf, Service



Kundert Ingenieure AG

Ifangstrasse 6, CH – 8952 Schlieren
 Tel. +41 44 755 42 42, Fax +41 44 755 42 43

www.kundert-ing.ch automation@kundert-ing.ch